

ZT-Meter

Model LZT

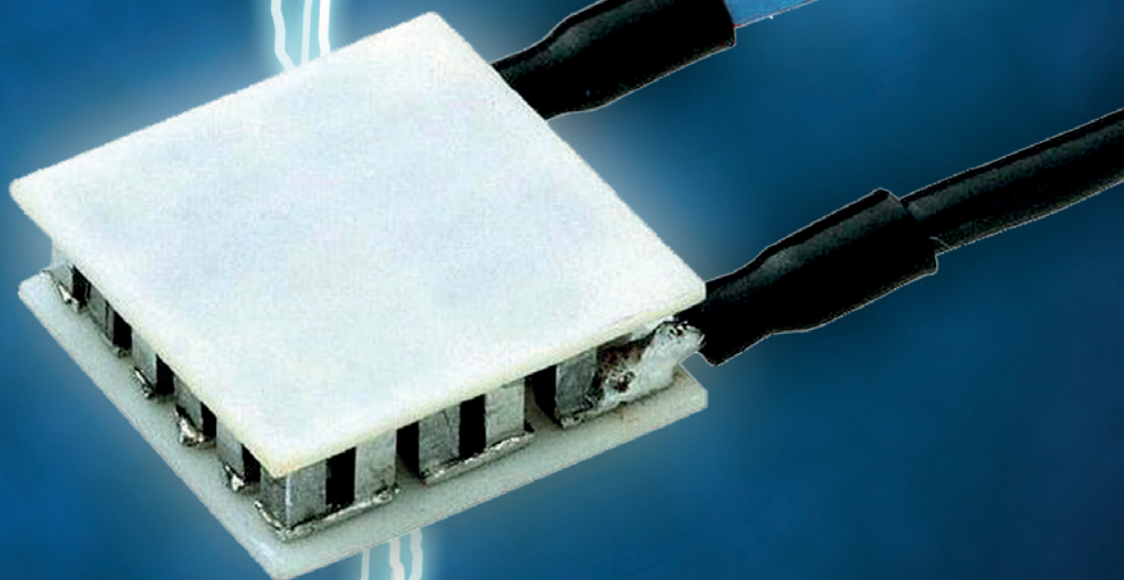

LINSEIS

LZT-Meter

Thermoelectricity describes the reciprocal interaction of temperature and electricity and their conversion into one another. There are three different effects—the Seebeck-Effect (Thermoelectric-Effect), the Peltier-Effect and the Thomson-Effect, which describe a reversible interaction between the both values. Nearly always these effects appear together.

Seebeck-Effect

With the Seebeck-Effect, a temperature difference creates an electrical potential along a metal or semiconductor.

The voltage was induced through thermo diffusion currents. With other words, the Seebeck effect is the direct conversion of temperature differences directly into electricity.

$$U_{\text{Seebeck}} = S \cdot \Delta T$$

S: Seebeck-coefficient T: Temperature difference

$$[U_{\text{Seebeck}}] = \text{V/K}$$

Thomas Johann Seebeck discovered this effect in 1821. He incidentally detected, that between two ends of a metal rod an electric voltage appears, if there is a temperature gradient between them. When he connected both ends, an electric current appeared and he detected the magnetic field using a compass needle. He used this effect for temperature measurements and invented the thermocouple.

Peltier-Effect

The Peltier-Effect is the inverted effect of the Seebeck-Effect. An exterior current produces a change of heat transport. This discovery was made 13 years after the Seebeck-Effect from Jean Peltier (1834). This effect appears, if two conductors with different electric heat capacity get in contact with each other and are driven by an exterior current, electrons flow from one conductor to the other.

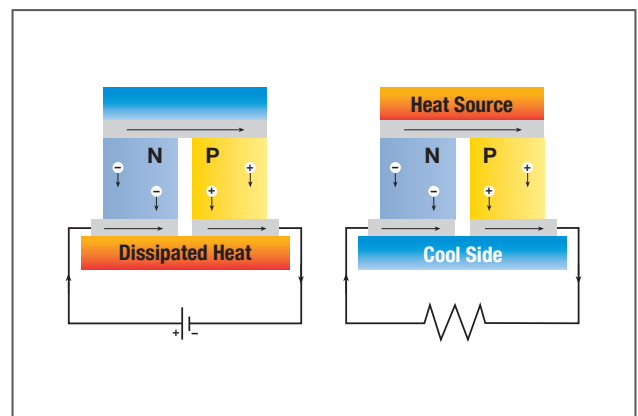

Field of Application

In recent years, thermoelectricity has been increasingly used in applications such as portable refrigerators, beverage coolers, electronic component coolers, and metal alloy sorting devices. Furthermore it is used in thermoelectric generators for waste heat recovery (for example in cars to decrease CO₂ emission) and solid state cooling or peltier-elements. Thermoelectric generators (TEG) are available since the early 1960s with a power output range from 10 to 550 W. Some advantages of the TEGs are a high reliability, long service intervals, low maintenance and a long durability. One of the most commonly used materials for such applications is Bismuth telluride (Bi₂Te₃), a chemical compound of bismuth and tellurium.

Thermoelectric Generators

Thermoelectric generators (also called thermogenerators) are devices which convert heat (temperature differences) directly into electrical energy, using a phenomenon called the „Seebeck effect“ (or „thermoelectric effect“). Their typical efficiencies are around 5-10%.

Early thermocouples were metallic, but many more recently developed thermoelectric devices are made from alternating p-type and n-type semiconductor elements connected by metallic interconnects as pictured in the figures below. Semiconductor junctions are especially common in power generation devices, while metallic junctions are more common in temperature measurement. Charge flows through the n-type element, crosses a metallic interconnect, and passes into the p-type element. If a power source is provided, the thermoelectric device may act as a cooler, as in the figure to the left below. This is the Peltier effect, described below. Electrons in the n-type element will move opposite the direction of current and holes in the p-type element will move in the direction of current, both removing heat from one side of the device. If a heat source is provided, the thermoelectric device may function as a power generator, as in the figure to the right below. The heat source will drive electrons in the n-type element toward the cooler region, thus creating a current through the circuit. Holes in the p-type element will then flow in the direction of the current. The current can then be used to power a load, thus converting the thermal energy into electrical energy.

LINSEIS has developed the first commercial ZT meter for bulk material in a broad temperature range -125° up to 1500°C. The system combines both a Laser flash and a Seebeck and Electric Resistivity Analyzer in one instrument.

Figure of Merit

Altenkirch (1909, 1911) showed that good thermoelectric materials should possess large Seebeck coefficients, high electrical conductivity and low thermal conductivity. These three values define the so called figure of Merit, ZT.

$$ZT = \frac{S^2 \cdot \sigma \cdot T}{\lambda}$$

S: Seebeck Coefficient; [*S*] = μV/K, *σ*: Electrical Conductivity; [*σ*] = 1/Ωm,

λ: Thermal Conductivity; [*λ*] = W/mK

The Figure of Merit is a value to compare the thermoelectrical quality of different materials.

Actually, the highest value of ZT is between 2 and 3. The range of 3 to 4 was considered as a competition to mechanical energy generators.

Innovative concept of LZT-Analyzer

The first commercial instrument worldwide to measure the Figure of Merit in one measurement.

Main advantages of all in one measurement:

same sample

same geometry

stoichiometry

same environmental conditions

temperature profile

atmosphere

humidity

Measurement principle

Seebeck Effect and Electric Resistivity

The following picture shows the design of the measurement system. The sample is in a vertical way between the upper and the lower block. The lower block includes a secondary heater that causes a temperature gradient. For the determination of the Seebeck-Coefficient the temperature difference and the thermo-electromotoric force dE (voltage) will be measured. The Seebeck-Coefficient can now be calculated with this formula:

$$S = \frac{-dU_{Th}}{dT}$$

dU_{Th} : thermal voltage

dT : temperature difference

Simultaneously the electric resistivity can be measured. Therefore a constant current at both side of the sample is applied. The voltage drop dV minus the thermo-electromotoric force dE subtracted by the current show the resistance.

$$R = \frac{dV - dE}{I}$$

R : Resistance

dV : voltage drop

dE : thermo-electromotoric force

I : current

With determination of the sample geometry and the distance of the thermocouples the electric resistivity can be calculated.

$$\rho = R \cdot \frac{A}{d}$$

ρ : resistivity

A : sample geometry

d : distance of the thermocouples

Therefore the design of the measurement includes the thermocouples, the current electrodes, a constant current power supply and the upper & lower block. The lower block includes a secondary heater and the whole installation is in a primary furnace.

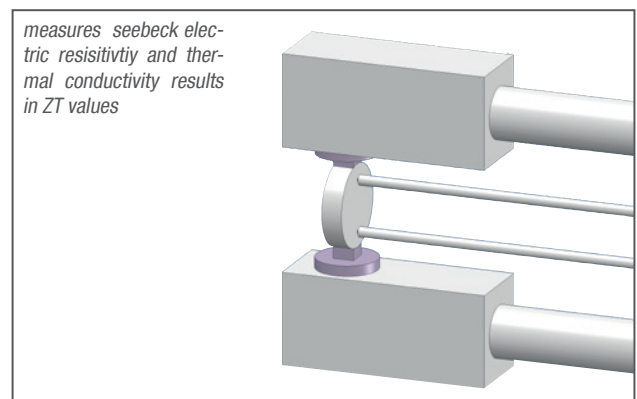
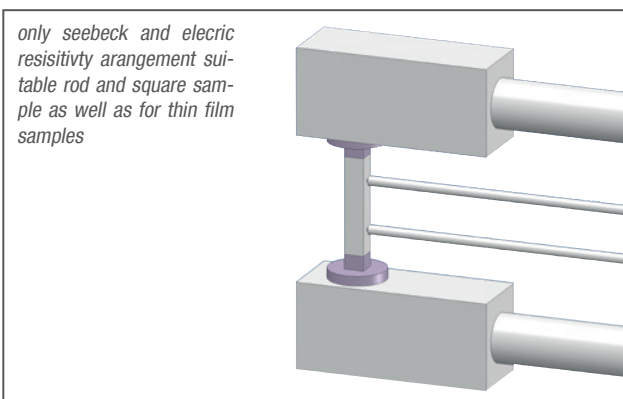
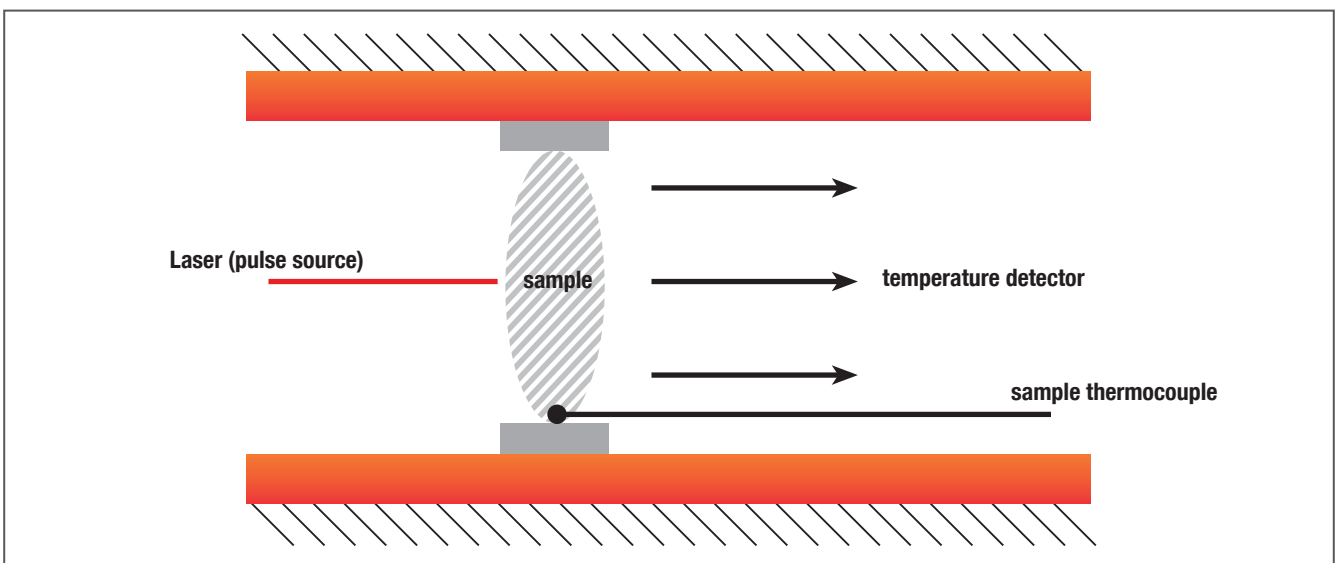

Thermal Conductivity / Thermal Diffusivity

Principal of Measurement: Laser Flash

The sample is positioned on a sample holder, located in a furnace. The furnace is then held at a predetermined temperature. At this temperature the sample surface is then irradiated with a programmed energy pulse (laser or xenon flash). This energy pulse results in a homogeneous temperature rise at the sample surface. The resulting temperature rise of the rear surface of the sample is measured by a high speed IR detector and thermal diffusivity values are computed from the temperature rise versus time data. The resulting measuring signal computes the thermal diffusivity, and in most cases the specific heat (C_p) data. If the density (ρ) is identified, the thermal conductivity can be calculated:

$$\lambda(T) = \alpha(T) \cdot C_p(T) \cdot \rho(T)$$

Correspondence with International Standards. The LINSEIS LFA and XFA operate in agreement with national and international standards such as: ASTM E-1461, DIN 30905 and DIN EN 821.

LINSEIS is offering an unparalleled modular system design for this Thermophysical properties Analyzer. It is possible to upgrade the temperature range (exchangeable furnaces/ measuring system) and the detector TC or optional InSb/MCT. This enables the user to start with a cost effective solution and upgrade the system whenever the budget allows or the measurement task requires it.

The whole design of the Laserflash-module device is illustrated in the following picture:

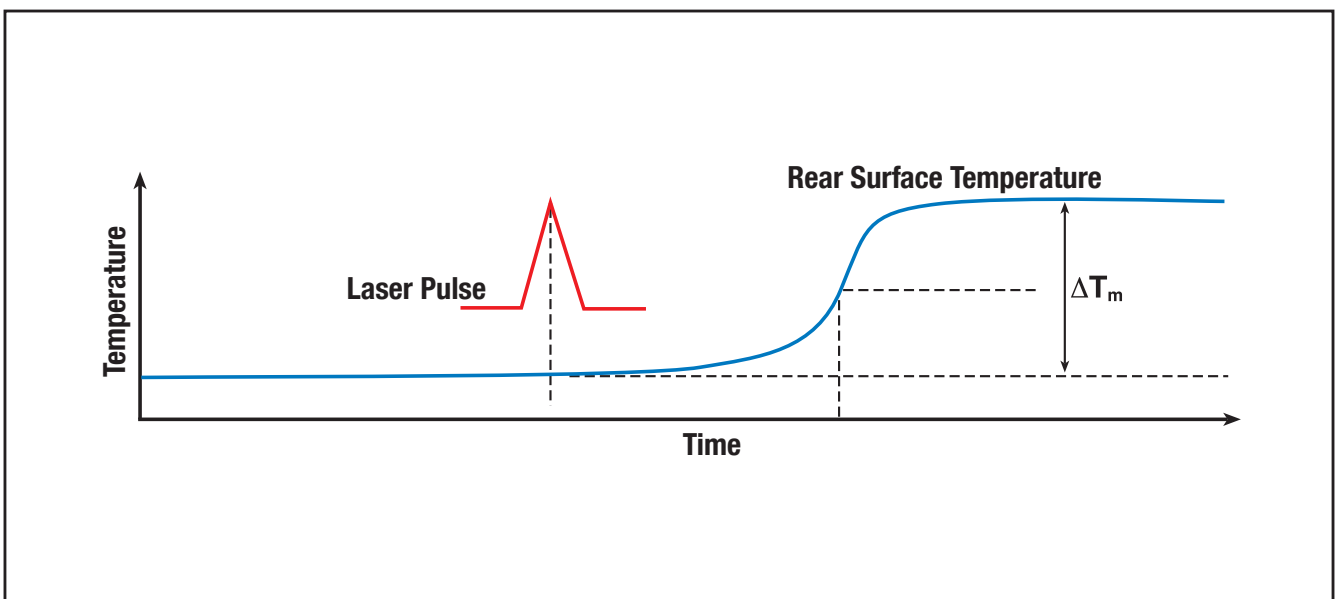

Applications

Measurement of a sample of the tellur family

A batch of samples of the tellur family enriched with bismuth and antimony $(\text{BiSb})_2\text{Te}_3$ was evaluated. As an example this can be a test series with changes in the chemical mixture and changes in the way the samples are manufactured. With the determination of the figure of merit one can evaluate which change of chemical mixture or which change in the production process generates the best figure of merit. The first diagram shows the thermal diffusivity R and the heat conduc-

tivity K in relation to temperature. The thermal diffusivity can directly be measured with the LFA (Laser Flash system), and with the density (from the Dilatometer measurement) and the specific heat C_p (from the DSC measurement) the heat conductivity λ can be calculated.

The second diagram shows the resistivity ρ and the Seebeck-Coefficient S of the LSR measurement. And in the third diagram the figure of merit is calculated.

Thermal Diffusivity (LFA-Measurement) and Heat Conductivity (Calculation) above temperature of $(\text{BiSb})_2\text{Te}_3$

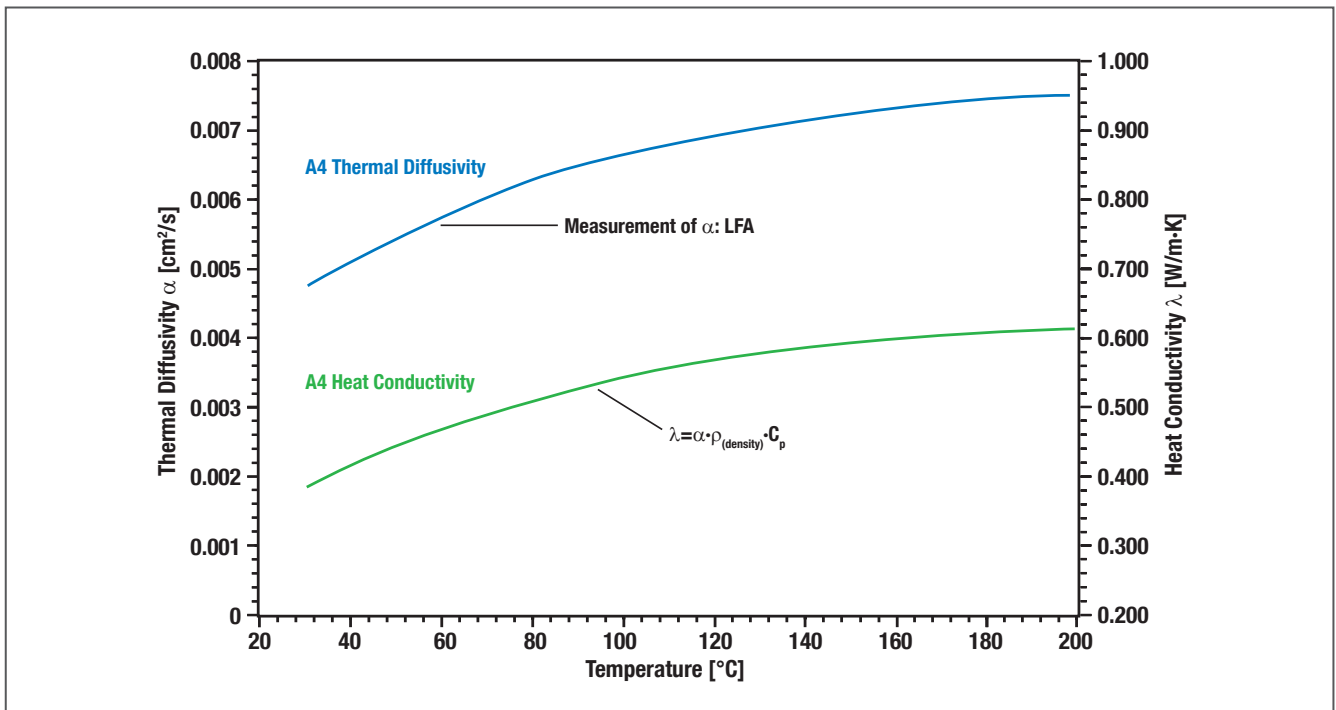

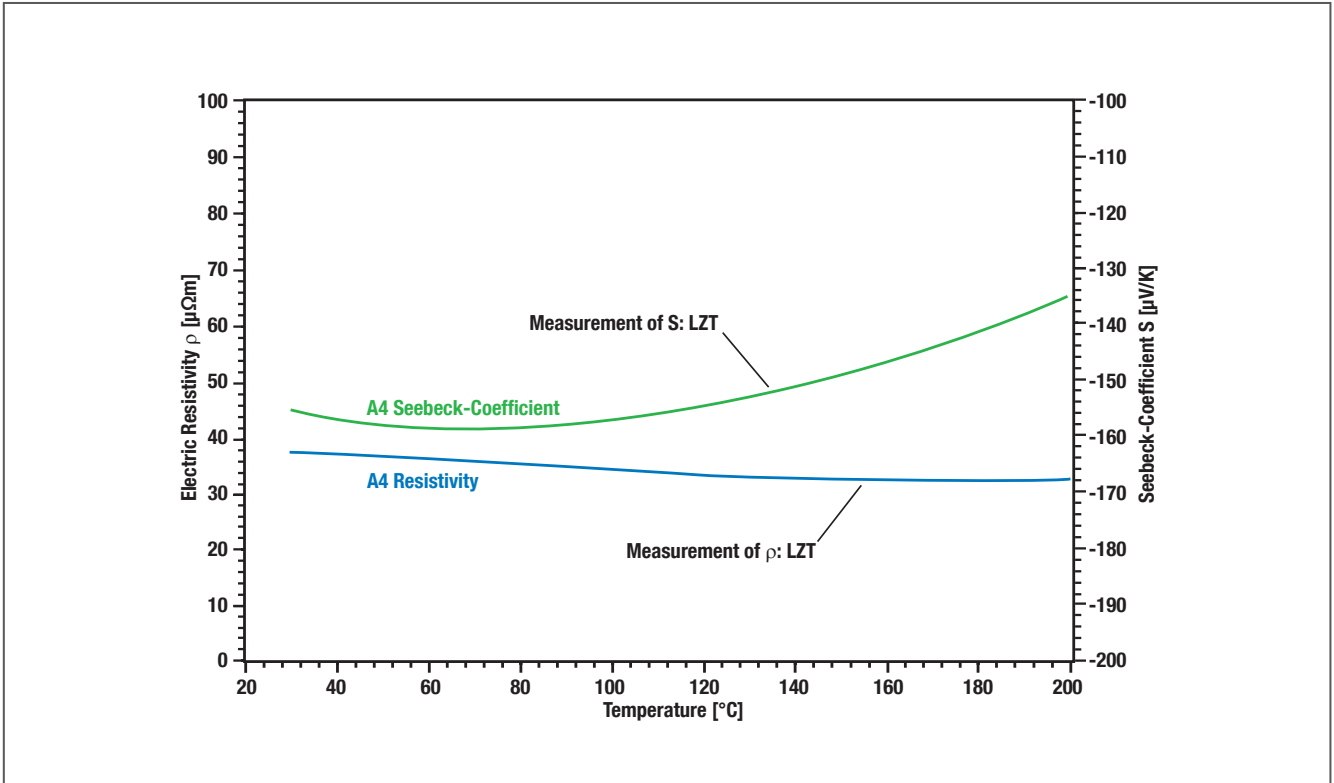
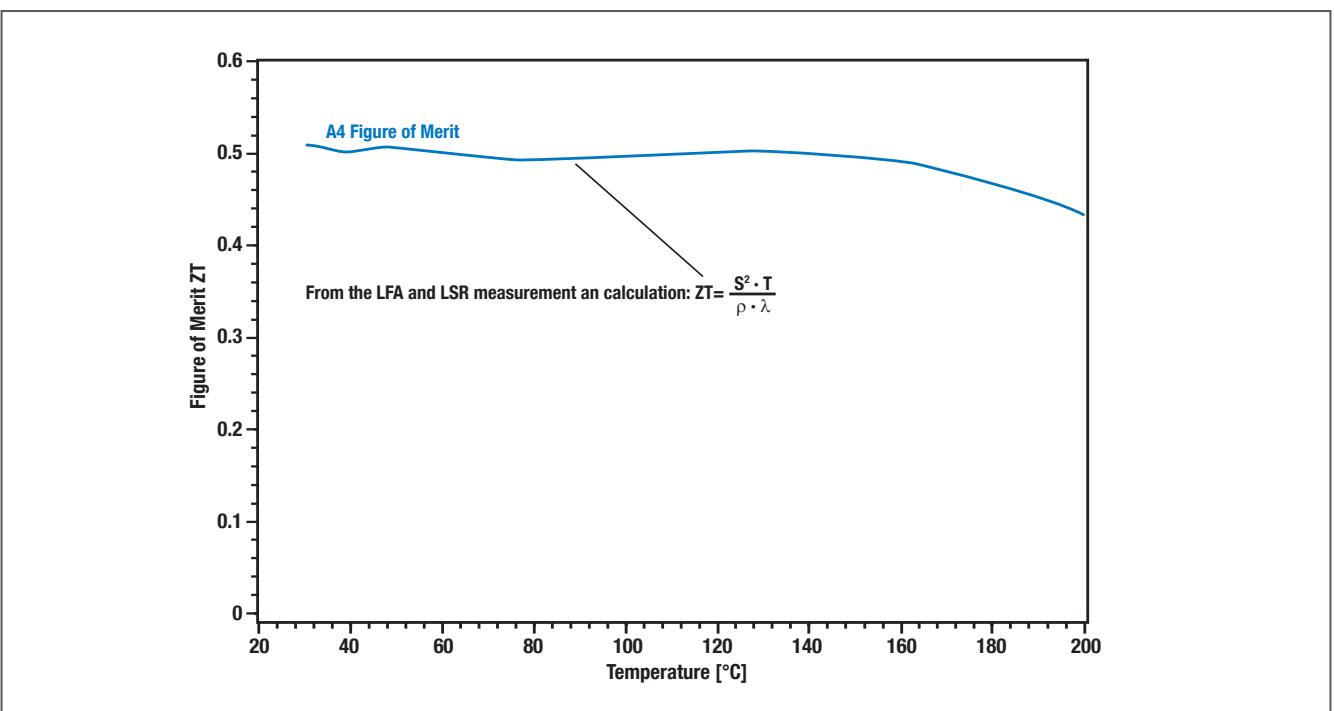

Figure of Merit (calculation) above temperature of $(\text{BiSb})_2\text{Te}_3$



Specifications

Temperature range	-150 up to 500°C; RT up to 800/1100/1500°C
Measurement method	Seebeck coefficient: Static dc method Electric resistance: four-terminal method
Specimen holder	sandwiched between two electrodes
Atmosphere	inert, oxid., red., vac.
Sample size	2 to 4 mm diameter x 6 to 23 mm long
Sample size round (Disc shape)	10, 12.7, 25.4 mm
Lead interval	4, 6, 8 mm
Cooling water	required
Thermal Conductivity	
Pulse Source	Laser Pulse: (25 Joule) Nd:YAG
Pulse duration	0.05 up to 5ms
Detector	InSb or MCT
Thermal Diffusivity	
Measuring range	0.01 up to 1000 mm ² /s

RMI, s.r.o.

Pernštýnská 116
533 41 Lázně Bohdaneč
Tel: 466 921 885, 404
e-mail: sale@rmi.cz
web: www.rmi.cz



LINSEIS GmbH

Vielitzerstr. 43

95100 Selb

Germany

Tel.: (+49) 9287-880 - 0

Fax: (+49) 9287-70488

E-mail: info@linseis.de



LINSEIS Inc.

109 North Gold Drive

Robbinsville, NJ 08691

USA

Tel.: (+1) 609 223 2070

Fax: (+1) 609 223 2074

E-mail: info@linseis.com



LINSEIS China

Kaige Scientific Park 2653 Hunan Road

201315 Shanghai

Tel.: (+86) 21 505 506 428 004

Fax.: (+86) 21 680 635 76



LINSEIS France

Bureaux Paris

52 Boulevard Sébastopol

75003 Paris

Tel.: (+33) 173-028 272

www.linseis.com

Products: DIL, TG, STA, DSC, HDSC, DTA, TMA, MS/FTIR, In-Situ EGA, Laser Flash, Seebeck Effect, Thin Film Analyzer, Hall-Effect

Services: Service Lab, Calibration Service



LINSEIS